

## Quick-Lock Seitenkofferträger BMW F 650 CS

### Montagehinweise

Fahren Sie nicht ohne Koffer mit montierten Seitenplatten. Wenn sie ohne Gepäck fahren, Seitenplatten demontieren.

Alle vom Motorrad gelösten Schrauben sind gemäß Herstellerangaben wieder zu montieren, oder mit von SW-MOTECH gelieferten Schrauben zu ersetzen. Falls nicht anderweitig definiert, diese Schrauben nach Tabelle anziehen.

M6	9,6 Nm
M8	23 Nm
M10	46 Nm

Gegebenenfalls Schrauben mit flüssiger Schraubensicherung einkleben.

Prüfen Sie nach 50 km alle Verbindungen auf festen Sitz.

Maximale Zuladung der Koffer :  
 Gemäß Herstellerangaben

SW-MOTECH GmbH & Co. KG

Ihr Ansprechpartner  
 -WÜDO-

Tel.: ++ 49 (0) 2301-91880  
 Mail: wuedo@wuedo.de

www.wuedo.de

### Mounting Instructions

German safety regulations require that no metal edge with a radius of less than 2.5mm be exposed while driving a motorcycle. Because Quick-Lock sidecase racks have edges with a radius of less than 2.5mm, Quick-Lock sidecase racks should not be used when luggage is not attached to them.

SW-MOTECH products should be installed by a qualified, experienced motorcycle technician. If you are unsure of your ability to properly install a product, please have the product installed by your local motorcycle dealer. SW Motech takes no responsibility for damages caused by improper installation.

All screws, bolts and nuts, including all replacement hardware provided by SW-MOTECH, should be tightened to the torque specified in the OEM maintenance manual for your motorcycle. If no torque specifications are provided in the OEM maintenance manual, the following torques may be used:

M6	9,6 Nm
M8	23 Nm
M10	46 Nm

All screws, bolts and nuts should be checked after driving the first 50 km to ensure that all are tightened to the proper torque.

Medium strength liquid thread-locker (i.e., "Loctite") should be used to secure all screws, bolts and nuts.

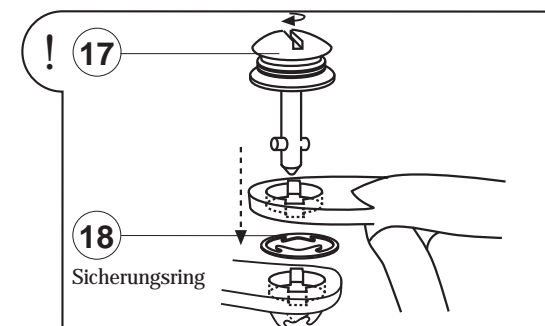
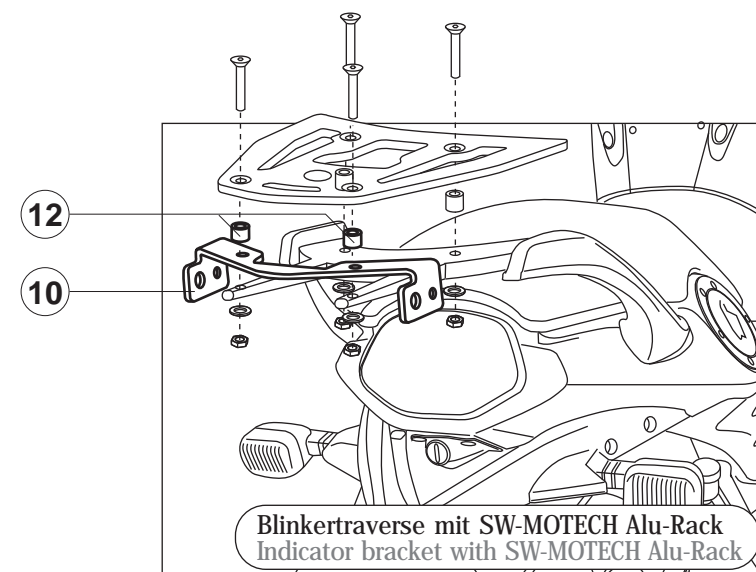

Zur Demontage des QUICK-LOCK-Kofferträgers einfach mit einer Münze oder einem Schraubendreher die Schnellverbinder lösen und Seitenträger entfernen.

Blinkertraverse mit original Träger.  
 Indicator-Bracket with the original rear carrier.

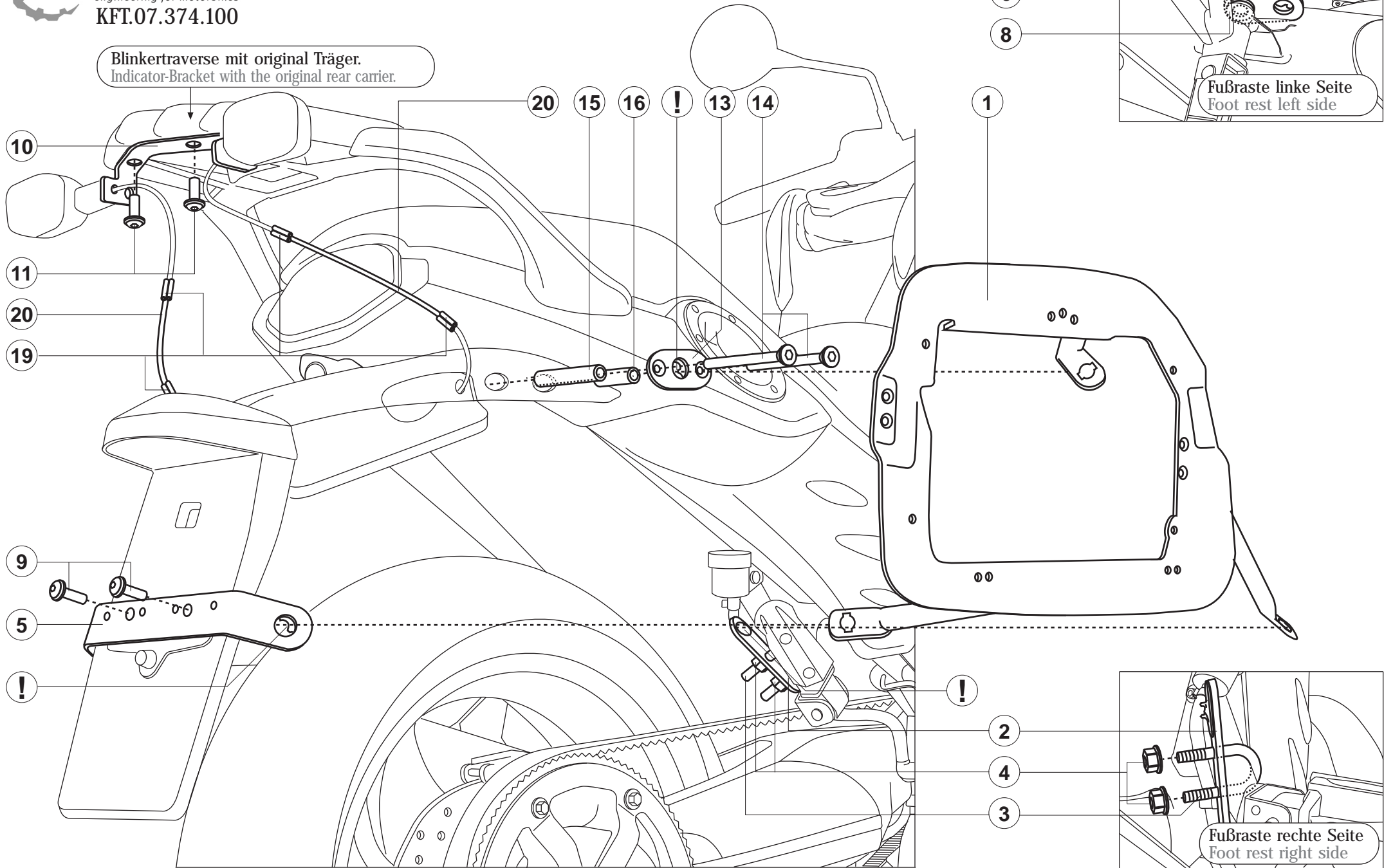

7

6

8

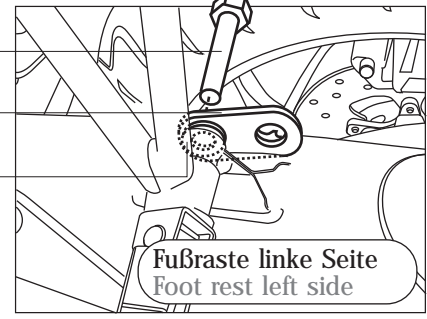

1

10

11

20

19

20

15

16

!

13

14

9

5

!

!

2

4

3

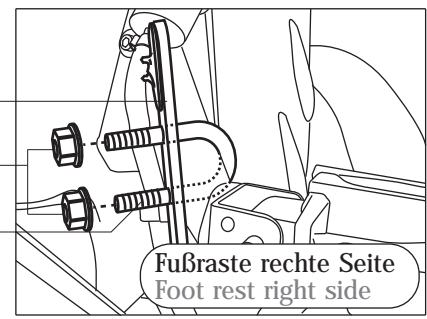

1 Koffertträger  
Side Bracket

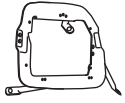

KFT.06.374.901/902 L/R

Anzahl/ Pcs. 2 (L/R)

5 Querverbinder  
Liscence Plate Bracket

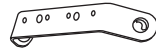

KFT.00.061.004

Anzahl/ Pcs. 1

9 Linsenschraube mit  
Innensechskant  
Lenshead Screw

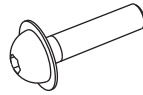

M5 x 20 ISO 7380

Anzahl/ Pcs. 2

13 Befestigungsblech  
Fixing Lug



KFT.07.374.001 Pos. 1

Anzahl/ Pcs. 2

17 Schnellverschluss  
Quick Fastener

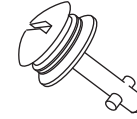

CAM.2312S11-12AF

Anzahl/ Pcs. 6

2 Befestigungsblech  
Fixing Lug



KFT.07.374.001 Pos. 2

Anzahl/ Pcs. 1

6 Befestigungsblech  
Fixing Lug



KFT.07.374.002

Anzahl/ Pcs. 1

10 Blinkertraverse  
Indicator Bracket



KFT.07.374.003

Anzahl/ Pcs. 1

14 Senkkopfschraube  
Countersunk Screw



M6 x 70 DIN 7991

Anzahl/ Pcs. 4

18 Sicherungsring  
Retaining ring



CAM.2312S10/1BP

Anzahl/ Pcs. 6

3 Bügelschraube  
U-Bolt

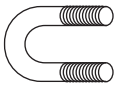

BUS.00.08.030.050

Anzahl/ Pcs. 1

7 Sechskantschraube  
Hexagon Screw



M10 x 40 DIN 933

Anzahl/ Pcs. 1

11 Linsenschraube mit  
Innensechskant  
Lenshead Screw

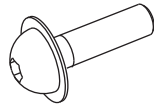

M5 x 20 ISO 7380

Anzahl/ Pcs. 2

15 Distanzbuchse  
Spacer



Da: 12; Di: 6.5; h: 47

Anzahl/ Pcs. 2

19 Kabelverbinder  
Cable Connector



STV.00.025.RD

Anzahl/ Pcs. 8

4 Mutter mit Bund,  
selbssichernd  
Lock Nut



M8 DIN 6927

Anzahl/ Pcs. 2

8 Unterlegscheibe  
Washer



A 10.5 DIN 125

Anzahl/ Pcs. 1

12 Distanzbuchse  
Spacer

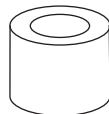

Da: 12; Di: 5.5; h: 9

Anzahl/ Pcs. 2

16 Distanzbuchse  
Spacer



Da: 12; Di: 6.5; h: 27

Anzahl/ Pcs. 2

20 Kabel  
Cable



KAV-100/4 250 mm

Anzahl/ Pcs. 2